



User Guide – Evaluation Kit

WLG-30-R range motor with embedded encoder

02/01/2024

Table of Contents

1. About Tekceleo

2. Conditions of use and best practice

- General Characteristics and Warnings

3. Evaluation Kit Presentation

- Kit's parts presentation

4. Technical Specifications

- Technical Datasheet

5. Mounting Recommendation

6. Control Specifications

7. Technical Support & Contact Informations

ABOUT US

Tekceleo is a forward-thinking technology company dedicated to innovation and the creation of cutting-edge solutions. With a commitment to excellence, we specialize in providing innovative solutions with advanced motion and aerosol generation technologies.

Our mission is to simplify and empower lives across various industries, including medical, pharma, aerospace, and industrial automation. Tekceleo's diverse team of experts collaborates to drive technological advancements and deliver results that exceed expectations. We're not just a company, we're a catalyst for progress, and we invite you to join us on this exciting journey.



KEY FACTS



2 Patent Families



A unique Know-How



75% of Sales Abroad

Conditions of Use

General Characteristics and Warnings

1. General Characteristics

- To operate continuously, the motor needs to dissipate heat. It is advisable to mount it on a metal cooling plate.
- Performances are ensured as long as the temperature of the motor remains under 60 degrees.
- We highly recommend to use a flexible coupling between the WLG-30 motor and the load in order to ensure performances.
- The controller can be shared through license agreement for customers who want to incorporate the electronics into their own systems.
- All our controller can directly control continuous movement with switches.
- Software can be shared and/or customized on demand.

2. Warnings

- For precise motion control it is necessary to use a microcontroller connected to the controller. In our evaluation kit we offer specific STM32 microcontroller with embedded demo software for easily handle our motors.
- The motor shaft must absolutely not be loaded by radial load more than specified : 10 N
- The motor must be mounted on cooling plate designed in order to better dissipate the heat emanating from the motor.
- Optimal size is aluminum plate with the specified dimensions : 30 x 30 x 5 mm.
- Make sure to screw the motor using the right screw length (M3x0,5 – 3 mm deep MAX in the motor).
- Please respect the recommended tightening torque for M3 screws : 0,9 Nm.

WLG-30-R – Kit Presentation

Evaluation kit for Tekceleo's Wavelling Technology

The purpose of this kit is for you to easily use, test, evaluate and implement Tekceleo's unique ultrasonic motors.

To understand more about our technology you can consult our website :

www.tekceleo.com

Tekceleo's team is here to help you moving forward in your use case, for information, this kit intended use is for :

- **Directly use** our technology, as this kit is a standalone system that can be already used.
- **Evaluate** our technology, in order to ensure its viability for your project
- **Prototype** : all the parts of this kit are modular and can be implemented in a prototype
- **Be integrated** directly in your device.



Kit Presentation – Presentation of Parts

Content and included parts of this kit



WLG-30-R



WLG-30 ECU



STM32
MICROCONTROLLER

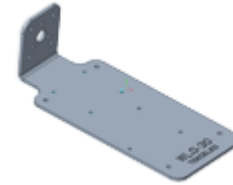

HEAT DISSIPATION
PLATE



7,5V POWER SUPPLY



CABLE ECU-MOTOR
(30CM)



FREE DEMO
SOFTWARE

Technical Specifications

WLG-30-R Datasheet

MOTOR DATA WITH EMBEDDED ENCODER	VALUES
Max No load speed	250 RPM
Stall torque	100 mN.m
Rated speed at maximum output	165 RPM
Rated torque at maximum output	75 mN.m
Holding torque	125 mN.m
Maximum power	1,3 W
Operating temperature	0°C to 60°C
MECHANICAL DATA	VALUES
Max radial load, 5mm from flange	10 N
Max axial load dynamics	2 N
Max force for press fits (static, shaft supported)	80 N
Shaft concentricity	± 0,075 mm
Weight	37,7 g
ELECTRICAL DATA	VALUES
Maximal power consumption	7,5 VDC / 1,35A
Recommended power supply	7,5 VDC / 2A
NON-MAGNETIC VERSION	YES

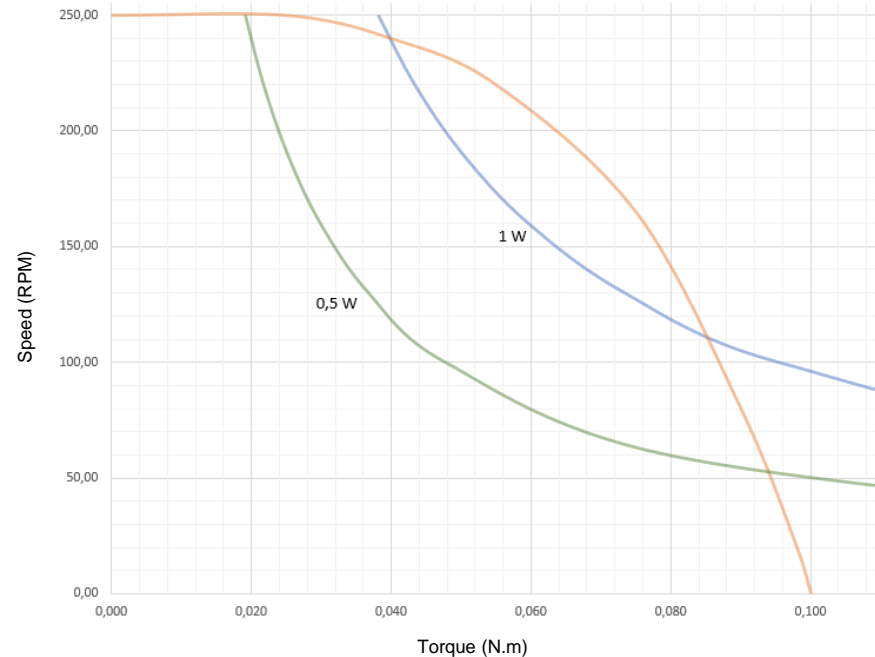

PRECISION	VALUES
Built-in encoder	Yes, optical with quadrature output
Max Encoder Resolution	0,0450° / 789 µr
Possible Max encoder Resolution (custom)	0,0104° / 181 µr

Technical Datasheet

WLG-30-R Dimensions

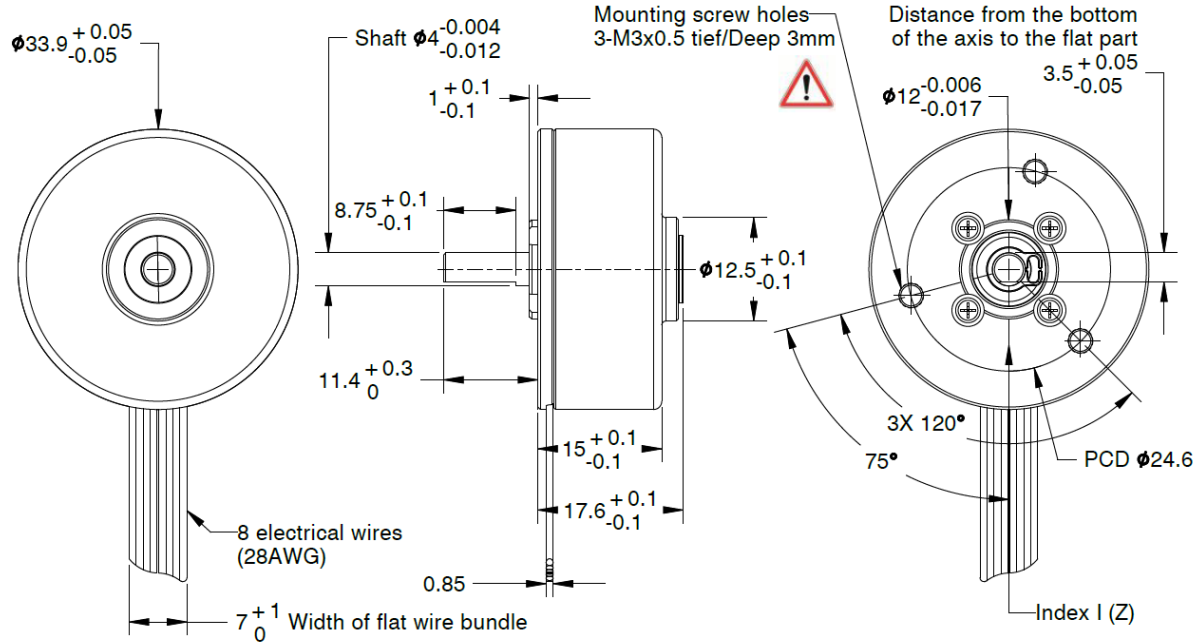

Embedded encoder:

Index I (Z) of the encoder is set perpendicular to the flat part of the driving axis, facing the 8 electrical wires.

Technical Datasheet

WLG-30-R Board dimensions

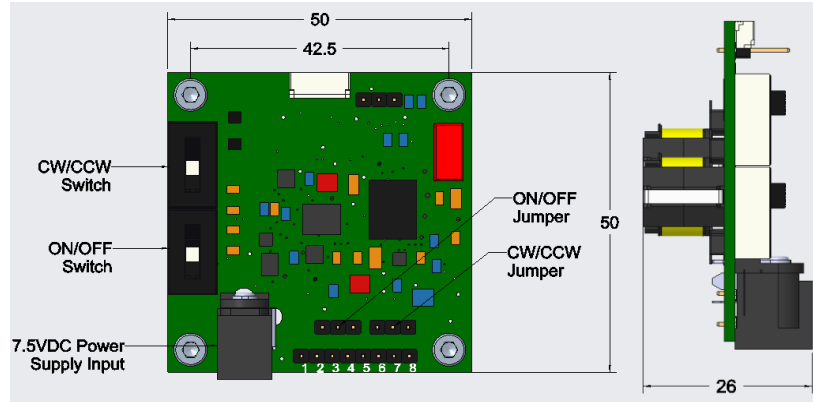

BOARD DIMENSIONS

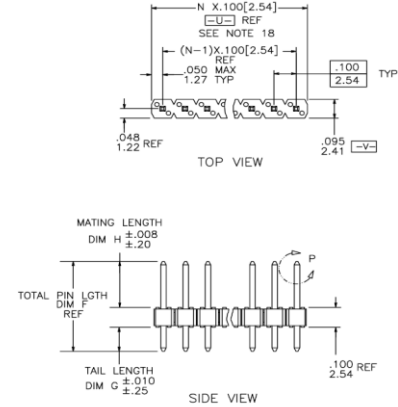

PINS DIMENSIONS

Mounting recommendations

Instruction to set-up and start the WLG-30 motor

- **Power up** : Connect the power supply into an electrical outlet.
- **Motor control** :
 - In order to turn on / turn off the motor, activate the on/off Switch.
 - To change the direction of the rotation, activate the **CW/CCW Switch**.
- **Speed control** : In order to control the speed and turn on the motor, connect the ground pin 2 and the speed pin 1 to a voltage generator. If the speed pin is not connected, the motor will not rotate.
- **Jumper settings** :
 - In order to control the motor via the manual switches, place the jumpers in the Switch Control position.
 - In order to control the motor via pin 3 and 4, place the jumpers in the External Control on pins 3 and 4 position.

PIN	INPUT / OUTPUT	SPECIFICATIONS
1	I	Speed control using analog voltage 0 – 3,3 VDC
2	-	Ground
3	I	On Off digital control TTL level signal (0 or 5 VDC)
4	I	CW / CCW digital control TTL level signal (0 or 5 VDC)
5	O	Incremental encoder signal A (2000 increments per rotation)
6	O	Incremental encoder signal B (2000 increments per rotation)
7	O	Incremental encoder index
8	-	Not used

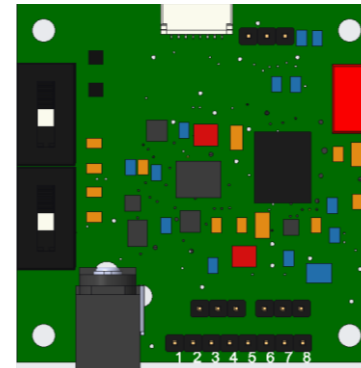

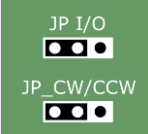
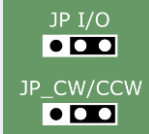
JUMPER CONFIGURATION	
Switch control	External control
	

Mounting recommendations

Instruction to set-up and start the WLG-30 motor



The motor shaft must absolutely not be loaded by radial load more than specified : 10 N



The motor must be mounted on cooling plate designed in order to better dissipate the heat emanating from the motor.

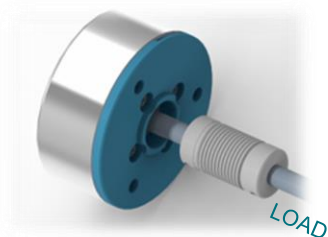

We highly recommend to use a flexible coupling between the WLG-30 motor and the load in order to ensure performances. Please find on the table the main characteristics to respect.

Our ref : A1233 from A.C.C.&S.

COUPLING CHARACTERISTICS	VALUES
Axial stiffness	2,2 N/mm
Radial Stiffness	4,2 N/mm
Inertial torque	3,6x10 ⁻⁷ kg.m ²



We recommend to fix the piezoelectric motor on a metal plate to dissipate the heat generated by the motor. Optimal size is aluminum plate with the specified dimensions : 30 x 30 x 5 mm



Make sure to screw the motor using the right screw length (M3x0,5 – 3 mm deep MAX in the motor). Please respect the recommended tightening torque for M3 screws : 0,9 Nm

Control specifications

Instruction to control the WLG-30 motor

CHARACTERISTICS	VALUES
On / Off response time (Pin 3)	< 500 μ s
Speed change response time	< 50 ms
Closed loop position controller (see figure below)	P control proportional
<u>In case you need to control the position of the motor :</u> In order to take advantage of the on / off response time of the motor, it is preferable to send a 0V on pin 3 once the motor has reached its position (see figure below)	
ENCODER DATA	VALUES
Two channel quadrature digital outputs for direction sensing : A and B	2000 increments per revolution each
One channel, Index digital output I (Z)	1 increment per revolution

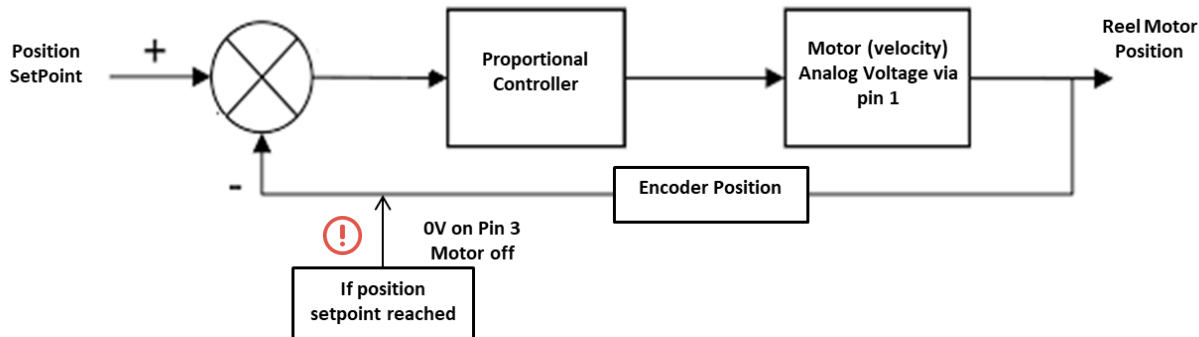
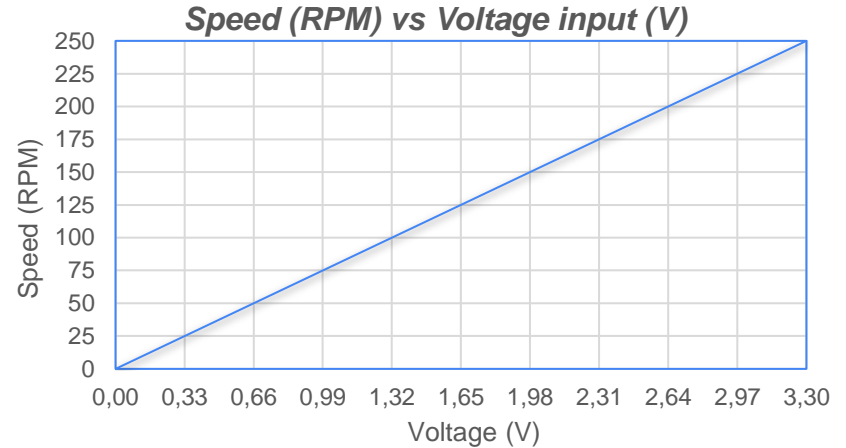

Evaluation Kit – Technical Support

Tekceleo's offer a complete technical support

- Directly contact your salesperson for any question. You can also directly contact Tekceleo using the contact@tekceleo.fr email address.
- In case of any trouble or issue you can freely open a support ticket by following this process :
 - Send an email to support-mot-1@tekceleo2.odoo.com
 - Object : order number + name of company
 - Content : explain the problem you're experiencing and join as many data, picture or video that you can to help us troubleshoot your problem.
- Tekceleo's team will get back to you as soon as possible to troubleshoot and resolve your problem.

At any point of your project you can contact Tekceleo's for help regarding uses, integration or development project. We can also offer customization and engineering services if needed.

CONTACT US



www.tekceleo.com



(+33) 04.92.28.05.16.



contact@tekceleo.fr



[LinkedIn](#)