



# User Guide – Evaluation Kit – P&S 360

*Electronic Sprayer Kit P&S 360-MXX Nebx01 IHM*

28/11/2023

# Table of Contents

## 1. About Tekceleo

## 2. Conditions of use and best practice

- *Warnings and best practice*
- *Maintenance*

## 3. Evaluation Kit Presentation

- *Kit's parts presentation*
- *Technical Datasheet*

## 4. Configuration

- *How to use the kit ?*
- *Fluidic System integration*
- *Cable management*

## 5. Electronic Control Methodology

- *Nozzle control*
- *Pump control*

## 6. Technical Support & Contact Informations

# ABOUT US

Tekceleo is a forward-thinking technology company dedicated to innovation and the creation of cutting-edge solutions. With a commitment to excellence, we specialize in providing innovative solutions with advanced motion and aerosol generation technologies.

Our mission is to simplify and empower lives across various industries, including medical, pharma, aerospace, and industrial automation. Tekceleo's diverse team of experts collaborates to drive technological advancements and deliver results that exceed expectations. We're not just a company, we're a catalyst for progress, and we invite you to join us on this exciting journey.



## KEY FACTS



**2 Patent Families**



**A unique Know-How**



**75% of Sales Abroad**

# Evaluation Kit – Conditions of Use

## Warning and Best Practices – General Maintenance

### 1. General Characteristics

#### Liquids :

- Reference liquid for standard use of H360 nozzles is Reverse Osmosis (RO) Water, with a  $>25 \mu\text{S}/\text{cm}$  conductivity.
- For operation, avoid use of liquid with conductivity inferior at  $15 \mu\text{S}/\text{cm}$  (i.e. pure or distilled water)
- For operation, avoid use of viscous liquid (information on demand)

#### Environment of Use :

- Nozzle can sustain a temperature from  $-20^{\circ}\text{C}$  to  $+85^{\circ}\text{C}$ , range of temperature can be increased on demand
- Nozzle can sustain very high relative humidity but avoid submerging it. Contact Tekceleo if your environment is not standard.

#### Common Risks :

- Clogging : nozzle can be clogged over time. Make sure to use a liquid that has low risk of deposit over time (filtered).
- Material compatibility : make sure to use liquid that are compatible with SS316L and HDPE.

### 2. Maintenance

#### Preventive maintenance :

In case of use of corrosive and/or liquid with risk of clogging, it is recommended to set a cleaning routine by purging the system and making it operates with RO or distilled water for a short period of time.

#### Cleaning :

Nozzle and system can be cleaned using ethanol-based biocide.

#### Corrective maintenance :

Use 1/100 white vinegar to unclog the nozzle, or organic solvent for more than 1 minute.

#### Best Practices :

- Always check the liquid you'll use, if you have any interrogation contact Tekceleo's team
- Setting up a regular cleaning procedure in case of risk with your liquid will greatly increase nozzle lifespan and performance

# P&S 360 – Kit Presentation

## Evaluation kit for Tekceleo's Micronice Technology

The purpose of this kit is for you to easily use, test, evaluate and implement Tekceleo's unique aerosol generation technology.

To understand more about our technology you can consult our website :

[www.tekceleo.com](http://www.tekceleo.com)

Tekceleo's team is here to help you moving forward in your use case, for information, this kit intended use is for :

- **Directly use** our technology, as this kit is a standalone system that can be already used.
- **Evaluate** our technology, in order to ensure its viability for your project
- **Prototype** : all the parts of this kit are modular and can be implemented in a prototype
- **Be integrated** directly in your device, as a precise spraying device.



# Kit Presentation – Presentation of Parts

Content and included parts of this kit



H-360 NOZZLE



ECU NEBx01  
MXx WITH CASING



500 ML  
TANK



3x30CM SILICONE  
TUBES



PROTECTIVE  
CAP



TRIPOD

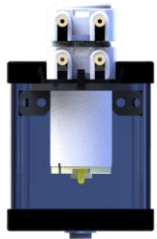

ECU PUMP  
+ PUMP



12V POWER  
SUPPLY



RCA CABLE



BNC CABLE



2x DC-DC  
CABLE



IHM P&S MXx

# Kit Presentation – Technical Datasheet

## H360 Nozzle Datasheet

H360 Nozzle Outputs			
Nozzle Ref	Droplet Size (+/- 15%)	Nominal Output ml.min (+/- 20%)	Nominal Output L.h (+/- 20%)
H360 – M05	05 µm	0,8 ml.mn	0,05 L.h
H360 – M08	08 µm	2,5 ml.mn	0,15 L.h
H360 – M12	12 µm	5,5 ml.mn	0,33 L.h
H360 – M20	20 µm	8 ml.mn	0,48 L.h
H360 – M50	50 µm	35 ml.mn	2,1 L.h

H360 Nozzle Inputs			
Nozzle Ref	Power Supply	Water Supply	Max Pressure inside system
H360 – M05	12 VDC – 60cm standard cable length  Connector : mini-XLR 3 pin Female	Circulating fluidic system with I/O plug for tubing	<0,1 bar  Working on circulating fluidic system
H360 – M08			
H360 – M12			
H360 – M20			
H360 – M50			

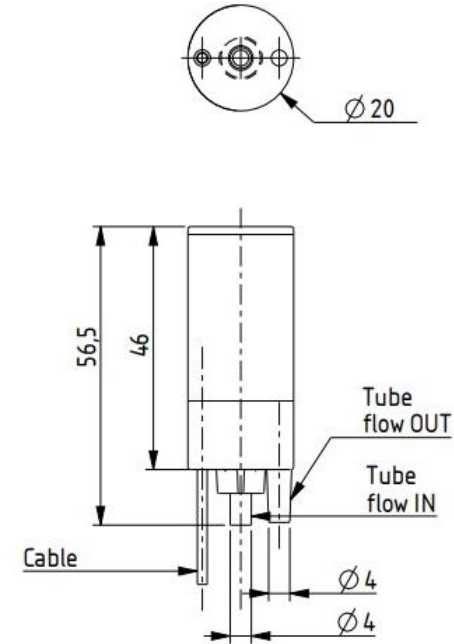

**H360 NOZZLE DIMENSION  
(3D FILES UPON REQUEST)**

# Kit Presentation – Technical Datasheet

## Electronic Control Unit (ECU) Datasheet

H360 Electronic Control Unit (ECU)	
Characteristics	Values
Supply Voltage	12 Vdc
Current Consumption (per nozzle)	180 mA – 250 mA
Nebulization	Led ON : ON Led OFF : OFF
Time Response	< 1,5 ms
Dimensions	120 x 66,5 x 32,5 mm
PWM Control	BNC Connector at 3,3 V Frequency : 150 Hz

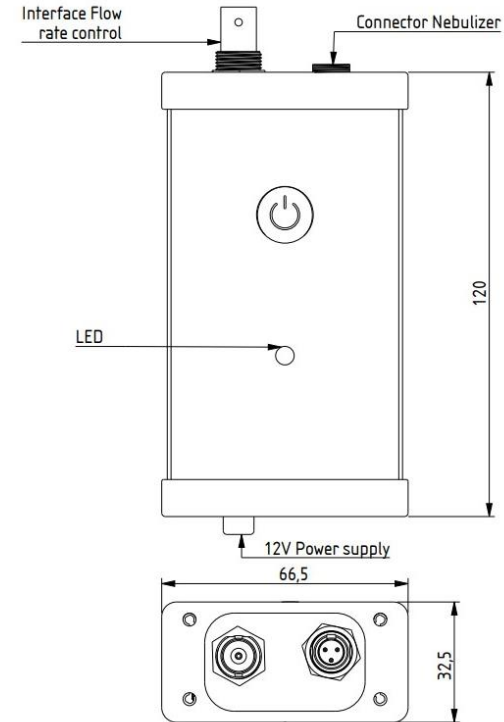

**H360 ECU DIMENSION  
(3D FILES UPON REQUEST)**



# Kit Presentation – Technical Datasheet

## Human Machine Interface (HMI) - Touch Screen Display

H360 Human Machine Interface (HMI)	
Characteristics	Values
Supply Voltage	12 Vdc
Current Consumption (per nozzle)	150 mA
Cables Length	<b>HMI Power Supply</b> : 80 cm <b>HMI – ECU cable</b> : 50 cm
Dimensions	<b>HMI</b> : 136 x 84 x 44,2 mm <b>Touch-Screen</b> : 3,5 inch
Pump and Nebulizer Control	Touch ON/OFF
Flowrate Control	Nebulizer : 1% increment from 0% to 100% Pump : 1% increment from 30% to 100%
Loop-Time Cycle Control	<b>Delay</b> : choice of time before beginning of a cycle <b>ON/OFF cycle</b> : choice of a time ON and a time OFF for alternating cycles <b>Number of Cycles</b> : choice of number of cycle or Infinite cycles

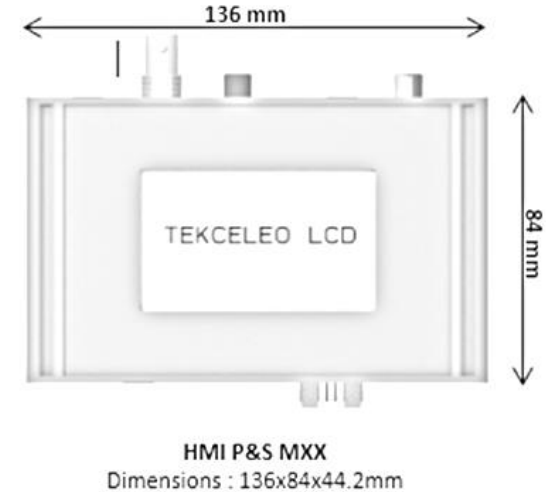

# Kit Presentation – Technical Datasheet

## Accessories : Pump and Reservoir

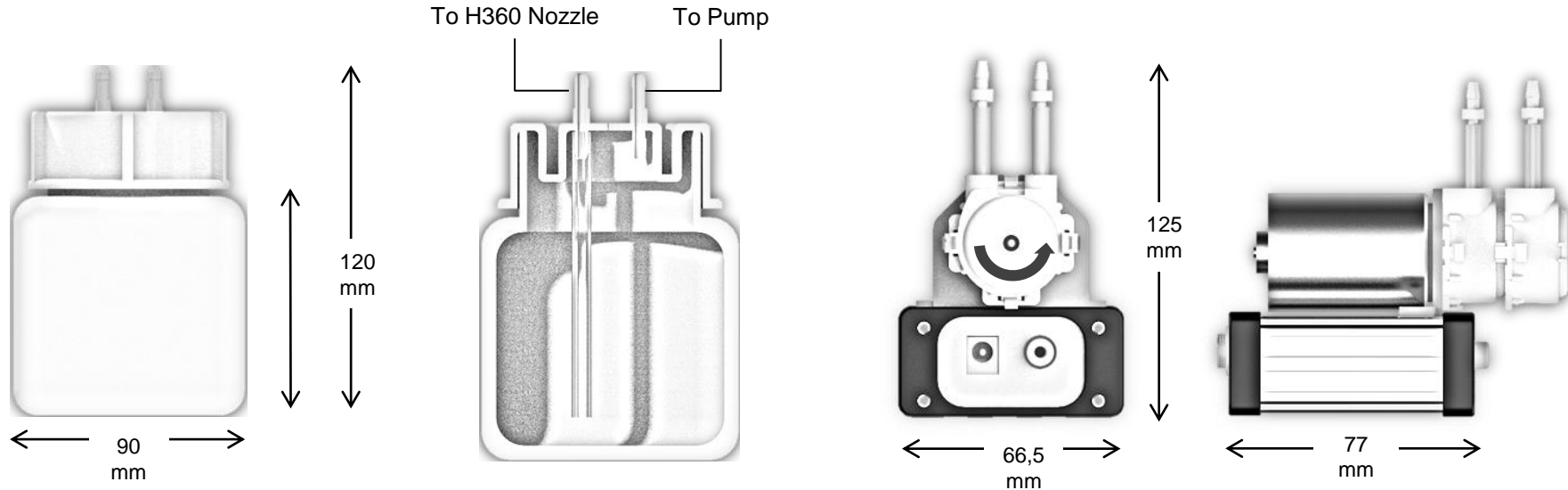

**STANDARD RESERVOIR DIMENSION  
AND FLUIDIC CONNECTIONS**

**STANDARD PUMP AND ITS ECU  
DIMENSION**

# Evaluation Kit – Configuration & Set-up

## Instruction to set-up and start the P&S 360 Kit

- Fill in the tank with liquid .
- Assemble the fluidic system with the H-360 electronic sprayer. Please make sure to respect the liquid circulation (see Page 5 and 6).
- For the electronic assembly please make sur to plug the 12V adapter to the 12Vin of the IHM P&S MXX at the very end :
  1. Connect the IHM P&S MXX to the ECU Pump ( CMD2-CMD2/12Vout-12V) and to the ECU NEBx01 ( BNC-BNC-12Vout-12V)
  2. Connect the H-360 electronic sprayer to the ECU NEBx01 via the mini XLR connector
  3. Connect the IHM P&S MXX to the power supply (12V adapter-12Vin) and then follow the instructions on the **IHM P&S MXX : Quick Start Guide**

HMI P&S MXX Control features : Loop Time Cycle Control	
<b>Flow rate</b>	Press "+" or "-" to select the nebulizer flow rate (0% to 100% variation).
<b>Delay</b>	Choice of x (seconds/minutes/ hours) which will correspond to the time before the beginning of a cycle.
<b>On/Off Cycle</b>	Choice of x (seconds/minutes/hours) ON and x (seconds/minutes/hours) OFF which will correspond to the activation and stop time after the end of the timer.
<b>Number of cycles or infinite</b>	Choose a number of cycles with the "+" or "-" buttons or select the "infinite" button to choose an infinite cycle. When the "infinite" button is activated, the number of cycles displayed is 0. Please deactivate the "infinite" button to choose an number of cycles.

# Evaluation Kit – Configuration & Set-up

## Cable Management Schematics



12V POWER SUPPLY

①



RCA CABLE

②



BNC CABLE

③



2X DC-DC CABLE

④

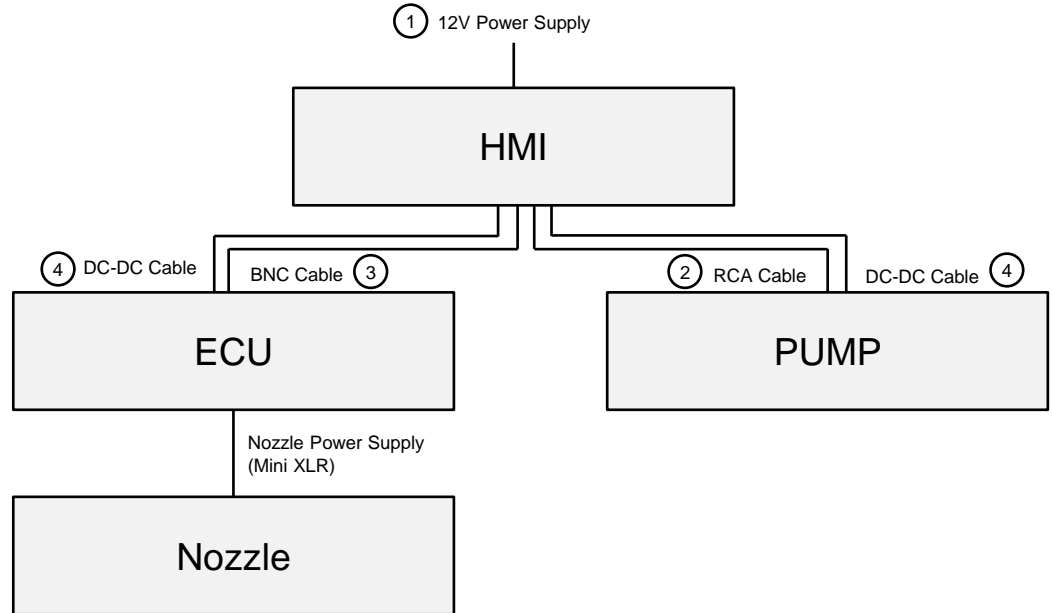

# Evaluation Kit – Configuration & Set-up

## Focus on Fluidic System Assembly

- Easy to set up.
- Plug all the tubes following the instruction.
- With this set up the pump will make the liquid circulate in a **vacuum mode**, thus avoiding any pressure on the nozzle.
- Test by priming the system to check that the liquid circulation is fine.

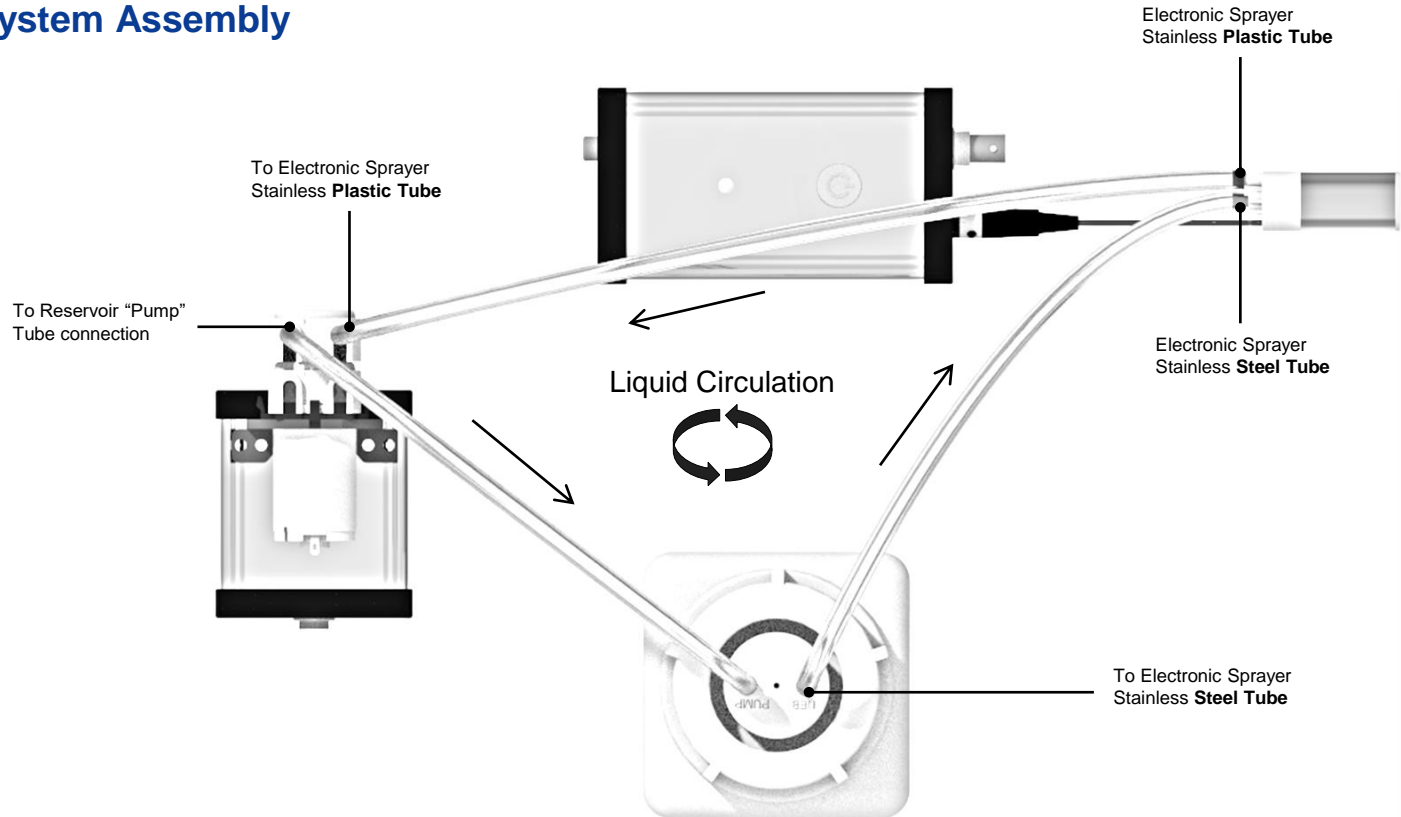

# Evaluation Kit – Electronic Control

## Overview of Control Methodology – Nozzle ECU

### Implementing ON/OFF and Flowrate Control with PWM :

- Use BNC Connector of the ECU 
- Default state of BNC connector is at 3,3V (ON)
- The uses terminals for PWM control are the following :
  - 100% Duty Cycle : ON (150 Hz frequency)
  - 0% Duty Cycle : OFF (150 Hz frequency)
- From 0% to 100% : flowrate is linearly proportional to the PWM duty cycle. Please refer to the attached graph.

### Relationship between Aerosol Flow Rate and PWM Duty Cycle

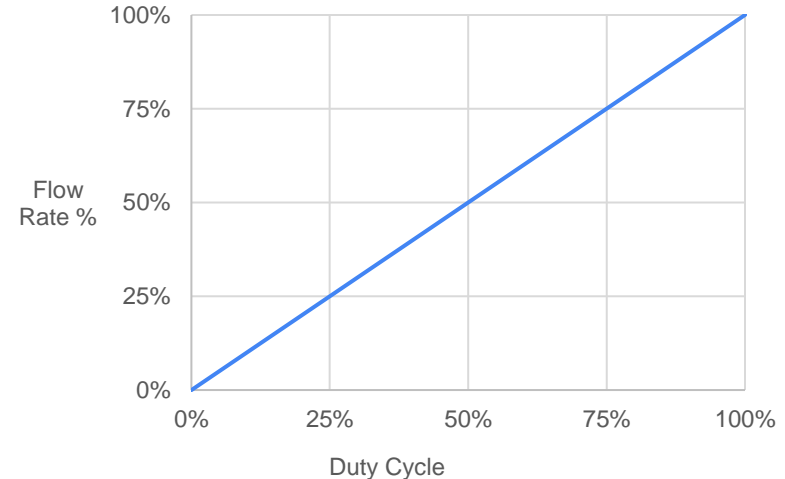

#### Important Notes :

- Default state of the electronic control is always ON when powered.
- Default state of the BNC Connector input is always 3.3V (ON by default).
- Any voltage superior than 3.3V could damage the ECU. Please contact Tekceleo if you want to use different setting. PWM connector can be adapted.

# Evaluation Kit – Electronic Control

## Overview of Control Methodology – Pump ECU

### Implementing ON/OFF and Flowrate Control with PWM :

- Use RCA Connector of the Pump ECU 
- Default state of RCA connector is at 3,3V (ON)
- The uses terminals for PWM control are the following :
  - 100% Duty Cycle : ON (150 Hz frequency)
  - 0% Duty Cycle : OFF (150 Hz frequency)
- From 50% to 100% : flowrate is linearly proportional to the PWM duty cycle. Please refer to the attached graph.

Relationship between Pump Flow Rate and PWM Duty Cycle

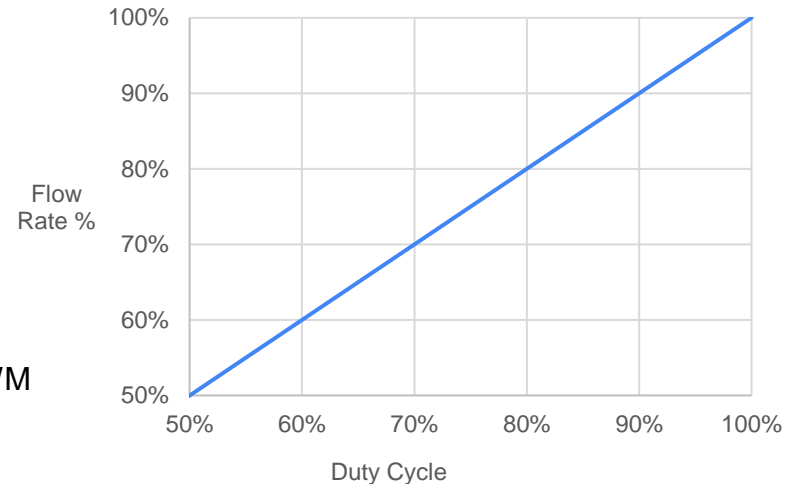

#### Important Notes :

- Default state of the electronic control is always ON when powered.
- Default state of the RCA Connector input is always 3.3V (ON by default).
- Any voltage superior than 3.3V could damage the ECU. Please contact Tekceleo if you want to use different setting. PWM connector can be adapted.

#### Pump and ECU specifications :

- Power supply voltage : 12 Vdc
- Pump max flowrate : 155 mL/min
- Current consumption : 0,5 A

# Evaluation Kit – Technical Support

## Tekceleo's offer a complete technical support

- Directly contact your salesperson for any question. You can also directly contact Tekceleo using the [contact@tekceleo.fr](mailto:contact@tekceleo.fr) email address.
- In case of any trouble or issue you can freely open a support ticket by following this process :
  - Send an email to [support-neb-1@tekceleo2.odoo.com](mailto:support-neb-1@tekceleo2.odoo.com)
  - Object : order number + name of company
  - Content : explain the problem you're experiencing and join as many data, picture or video that you can to help us troubleshoot your problem.
- Tekceleo's team will get back to you as soon as possible to troubleshoot and resolve your problem

At any point of your project you can contact Tekceleo's for help regarding uses, integration or development project. We can also offer customization and engineering services if needed.



# CONTACT US



[www.tekceleo.com](http://www.tekceleo.com)



(+33) 04.92.28.05.16.



[contact@tekceleo.fr](mailto:contact@tekceleo.fr)



[LinkedIn](#)