

HIGH PERFORMANCE AEROSOL GENERATORS AND NEBULIZERS

INTEGRATION/INSTALLATION MANUAL
MICRONICE® - H360 NOZZLE



1. Table of contents

- 1. Table of contents 1
- 2. Cautions and Warning 2
 - 2.1. Security Instructions 2
 - 2.2. Dimensioning 2
 - 2.3. Conditions of Use 2
 - 2.4. Handling Conditions 2
- 3. Elements Presentations 3
 - 3.1. Nozzle Presentation 3
 - 3.2. Power supply cable and connectors 3
- 4. Installation Rules 4
 - 4.1. Nozzle Installation 4
 - 4.1.1. Caution and Warnings 4
 - 4.1.2. Radial mounting 5
 - 4.1.3. Gasket Installation 6
 - 4.1.4. Axial Mounting 7
 - 4.2. Fluidic system Assembly 7
 - 4.2.1. Cautions and warnings 7
 - 4.2.2. Pump System 8
 - 4.2.3. Valve Mounted System 8
 - 4.3. Cable Management 9

2. Cautions and Warning

2.1. Security Instructions

- Mounting and Conditioning of the nebulization system must be done by a staff whom have been trained and whom are skilled, at risk of causing damage to the elements.
- Be sure to consider and follow the instructions stated in the present Manual and User Guide.
- Do not burn, swallow or absorb any part of the elements.
- Do not touch directly any electronic parts or components when the elements of assembly is powered.

2.2. Dimensioning

- All installation projects require a preliminary study of the required set up and functionality to be able to determine feasibility.
- A verification of the dimensioning of each components of a set up must be carried out before finalizing a proper installation. A focus on the sizing of the fluidic system, as well as on the number of nozzles and their location, will be particularly critical.
- Electronics components need to be compatible with the elements, their numbers, locations and eventual cable length required for their integration.
- Do not use custom power cable or electronic components linked to the system operations without written consent of Tekceleo.

2.3. Conditions of Use

- Elements need to be used in an environment between 0°C – 55 °C with a relative humidity comprise between 0% to 75%.
- Nozzle elements flowrate is validated and guaranteed with H₂O₂ with conductivity > 25µS.cm at 25°C temperature. Flowrate is not guaranteed for every liquid and conditions of use.
- Corrosive liquid can harm the system. Nozzle element is compatible only with liquid with low to no corrosiveness to Stainless Steel, HDPE and Silicon.
- Beware of clogging, that might happen with presence of particles in the liquid used. In case of clogging, please use a compatible solvent to unclog the nozzle.

2.4. Handling Conditions

- When handling the Nozzle always keep the protective cap on the spray head.
- Avoid use of any sharp tool around the spray head.
- Avoid direct touch of the Membrane Components of the Nozzle.
- Respect force limit to be applied to the Elements when mounting or handling. See Elements presentation on part 3. And Installation Instructions on part 4.1. for more information.
- Do not disassemble the Nozzle or its tubing.

3.Elements Presentations

3.1. Nozzle Presentation

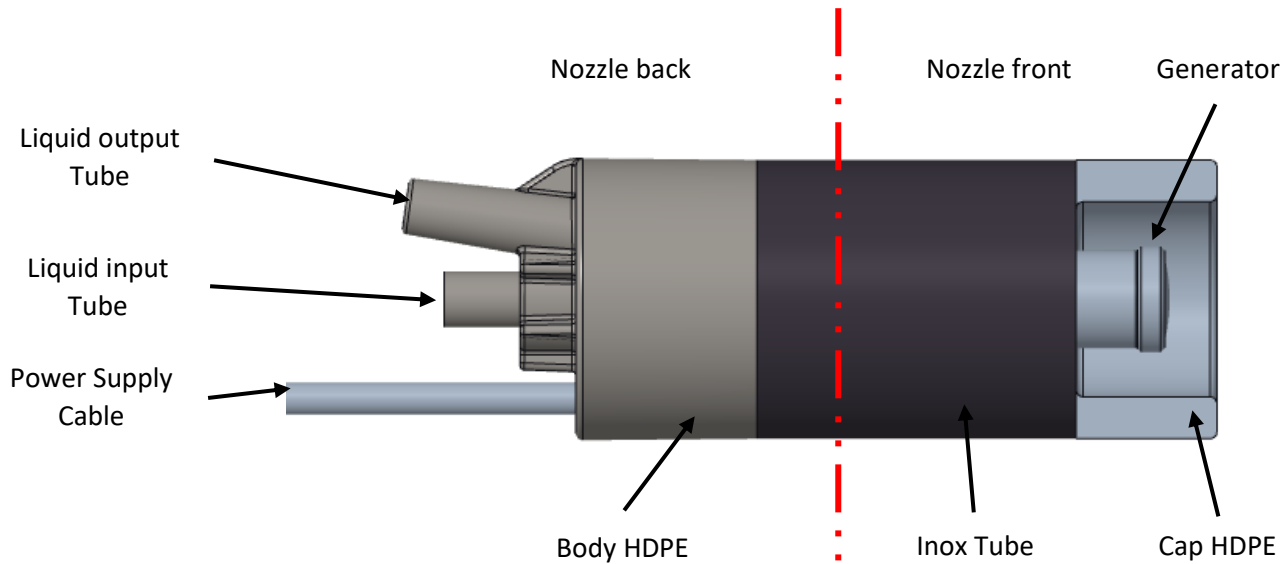

3.2. Power supply cable and connectors

Nozzle power cable and connectors are the following :

- Cable : 12 or 24 VDC – 60 cm standard cable length.
- Connector : Microfit 3.0 2P
- Cable Sheath : PVC
- Gauge : 32 AWG

4. Installation Rules

4.1. Nozzle Installation

4.1.1. Caution and Warnings

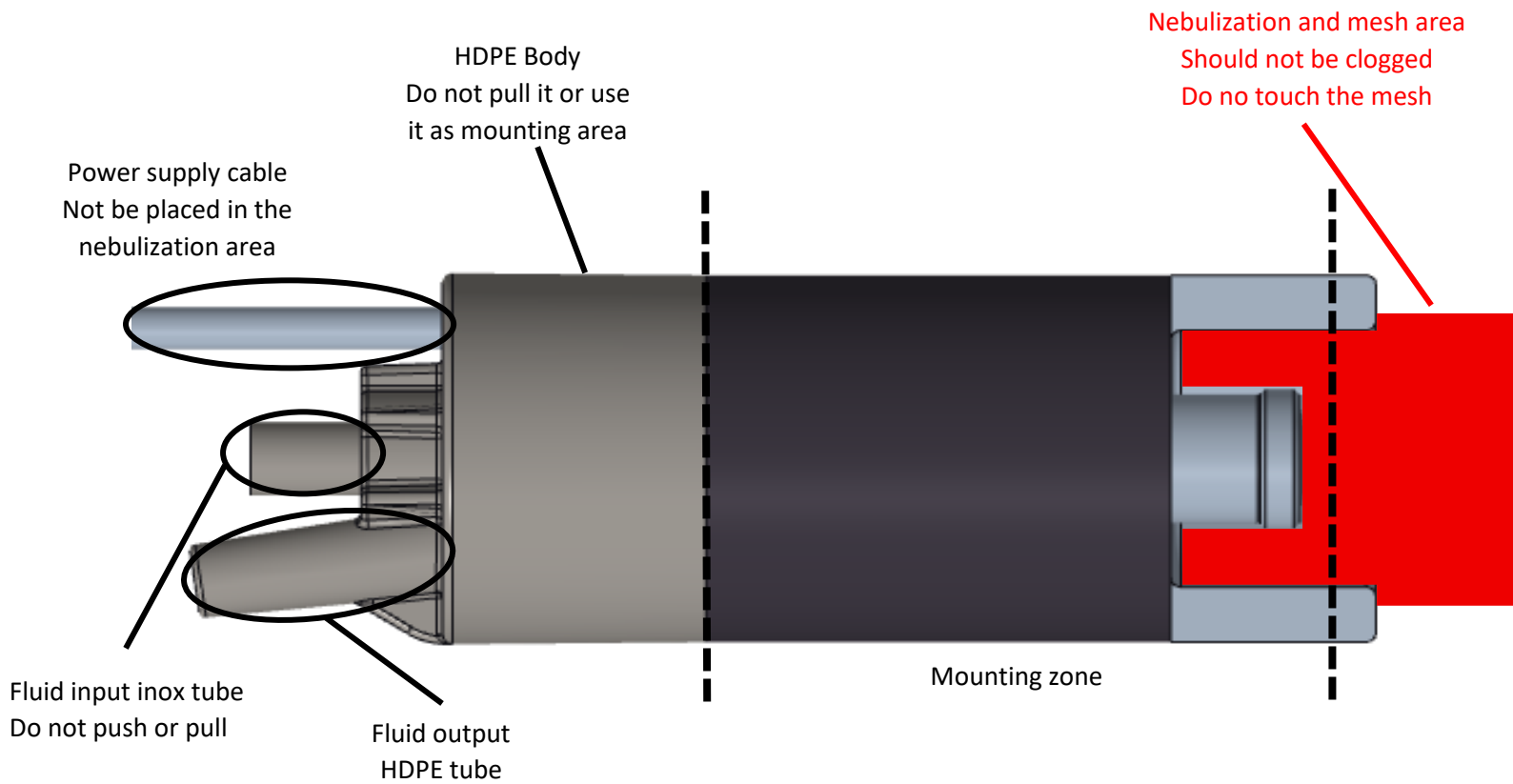

4.1.2. Radial mounting

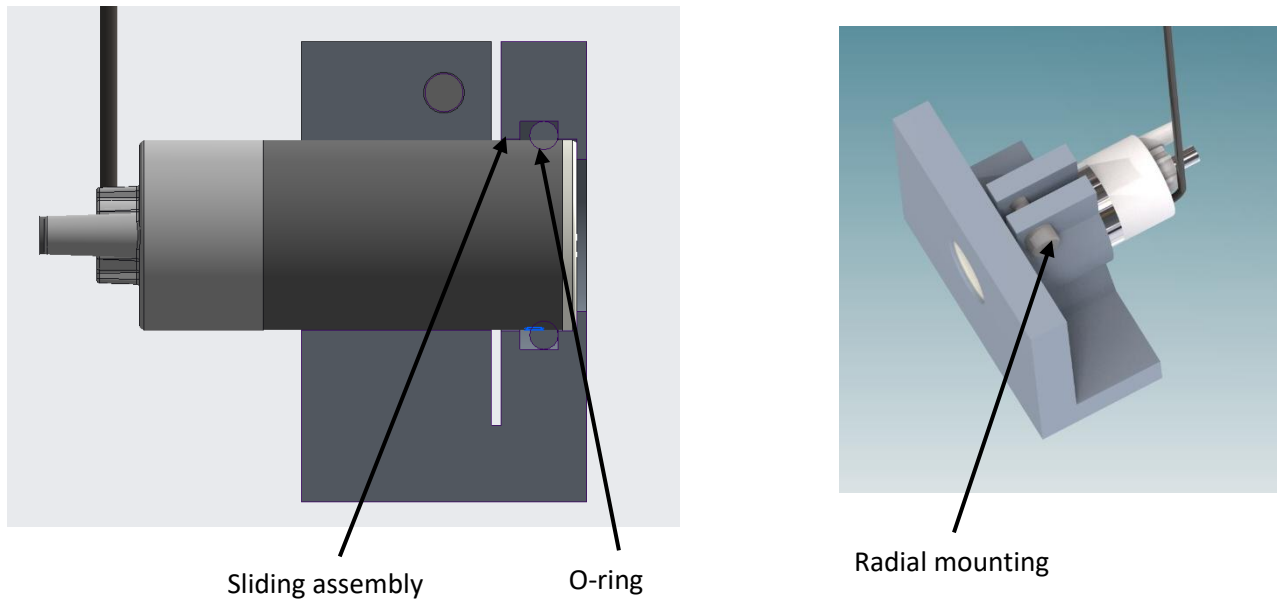
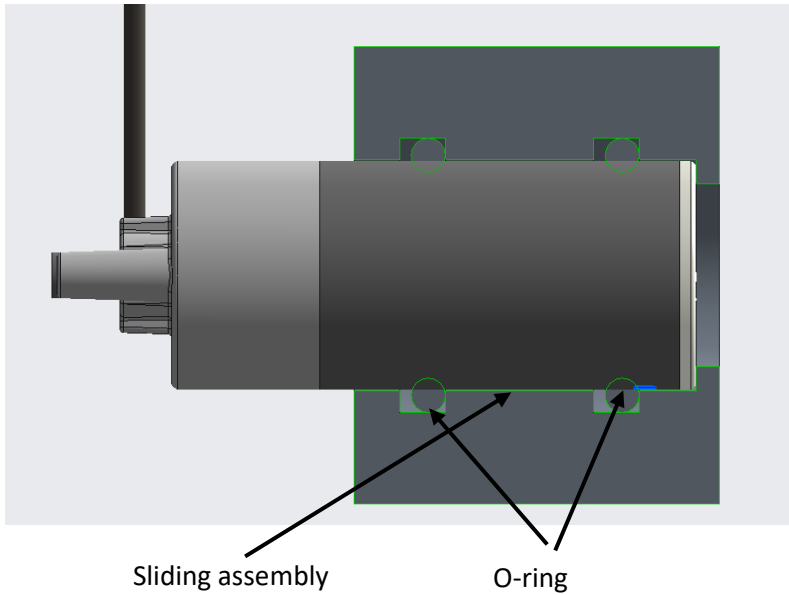

Figure : Radial Mounting Example

- Slip-on nozzle in part without radial clamp.
- A gasket (compatible with liquid used) is needed to ensure a complete sealing between the front of the nozzle and the rear.
- Axial stop can be made (optional) in front of the nozzle for more practical handling. If implementing an axial stop, ensure that it is not obstructing in any way the front of the nozzle (do not exceed the thickness of HDPE cap of the nozzle).
- Radial mounting can be done in different ways:
 - o Clamping by deformation of the support (concentric clamping) using a screw or other clamping device
 - o Clamping with radial dead bolts
- **Make sure that the mounting allows disassembly of the nozzle if needed, without the need of tooling.**

4.1.3. Gasket Installation



- Mounted slidingly in the holder.
- 2 thoric seals (compatible with liquid used) must hold it in position, and guarantee a complete sealing between the front and rear of the nozzle.
- Assembly must be done “by hand” (no press, hammer...) to not harm the nozzle in the process.
- **Make sure that the mounting allows disassembly of the nozzle if needed, without the need of tooling.**

4.1.4. Axial Mounting

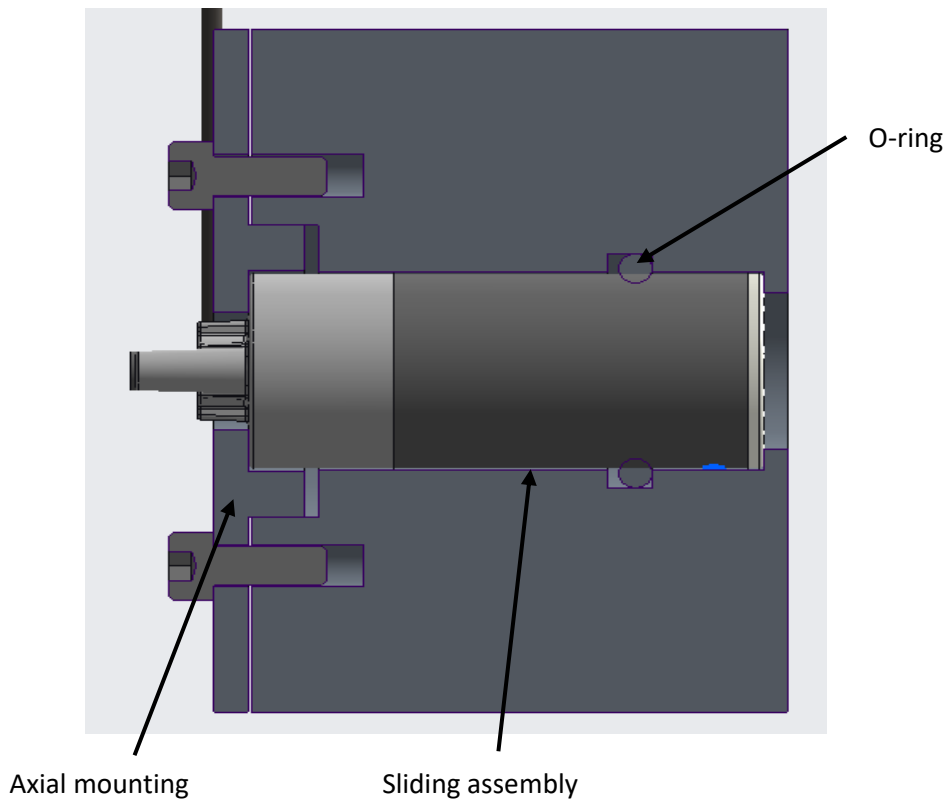

- Slide-mounted in holder.
- Thoric gasket (compatible with liquid used) ensures a complete sealing between the front and rear of the nozzle.
- Axial mounting is achieved by means of a plate at the rear which holds the nozzle clamped in the axis, against the shoulder at the front of the nozzle.
- **A sufficient space in the plate is required to expose the 2 water supply tubes and cable and ensure an easy dissembling of the nozzle if needed (without using any tools).**

4.2. Fluidic system Assembly

4.2.1. Cautions and warnings

- Fluidic pressure applied to the system should not exceed 0,1 bar.
- Fluidic system must always ensure fluid circulation through the nozzle. Always make sure that the Input and Output tubes of the nozzles are connected to your fluidic system and not blocked.
- Internal diameter of input tubes needs to be 3 or 4 mm ID.
- Ensure that the top of the reservoir is below or at nozzle height.
- Do not exceed applied water column height > 10 cm.

- Use flexible tubing: shore hardness 60A max.
- Manual installation of tubes on nozzle: max. axial force 30N.
- Tube weight must not be supported by the nozzle.

4.2.2. Pump System

- Liquid needs to be sucked through the nozzle, never pushed into the nozzle.
- Compatible pumps are pumps that allows suction mode with a stable rate.
- Pump capacity needs to be tested on final tube length and number of nozzles used before validation.
- Reservoir need to be below or same level than the nozzle in order to not put any static pressure on the nozzles.

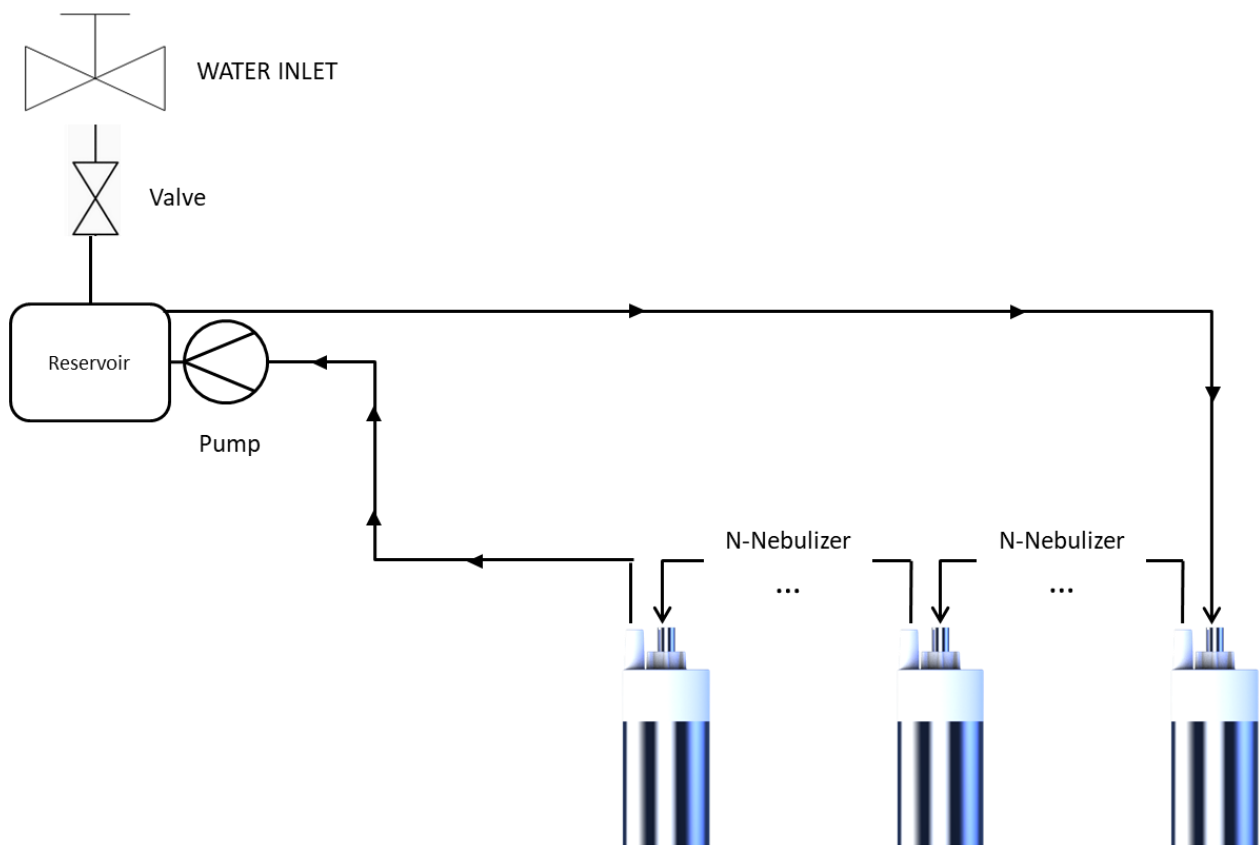

4.2.3. Valve Mounted System

- In case of direct use with a valve mounted system (i.e. tap-mounted) always use a pressure regulator < 0,1 bar.
- Always keep a flowing drain at the end of the fluidic system to avoid any pressure build up inside the nozzles.

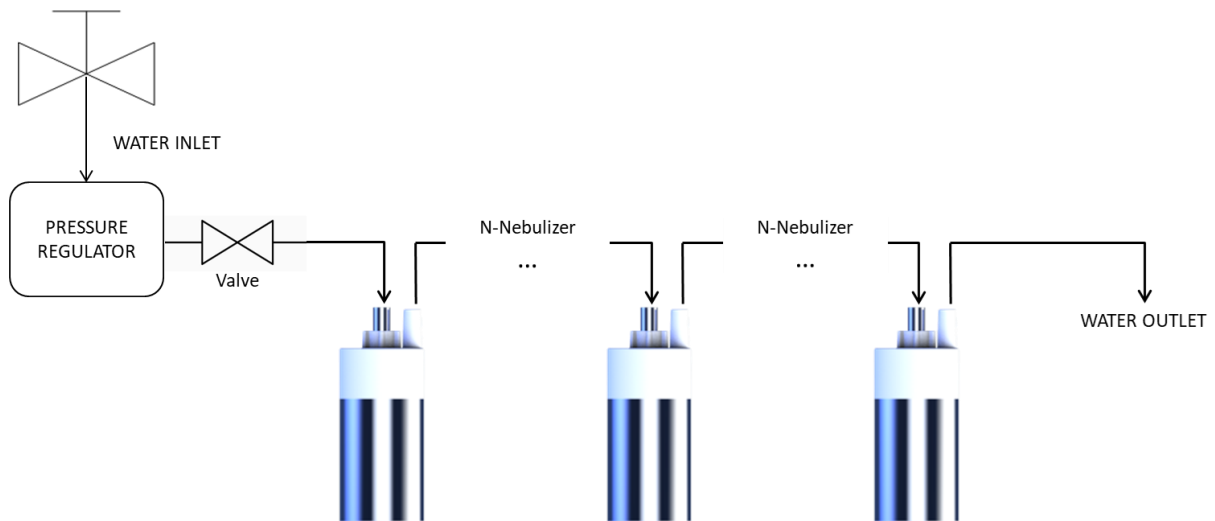

4.3. Cable Management

- Do not put any load on the power supply cable of the nozzle and its connector.
- Power supply cable of the nozzle is not designed to hold nozzle in place. Make sure the cables are secure and not subject to mechanical stress.
- Do not apply friction or other stresses to the cables.
- Ensure that cable and connectors are not in the nebulization area.



Contact us at :

www.tekceleo.com