



User Guide – Evaluation Kit – P&S T45

Electronic Sprayer Kit P&S T45

2025 - 2026

Table of Contents

1. About Tekceleo

2. Conditions of Use and Best Practice

- *Warnings and best practice*
- *General maintenance*

3. Evaluation Kit Presentation

- *Kit's parts presentation*
- *Technical datasheet*

4. Configuration

- *How to use the kit ?*
- *Fluidic system integration*
- *Cable management*

5. Electronic Control Methodology

- *Nozzle control*
- *Pump control*

6. Technical Support & Contact Informations

ABOUT US

Tekceleo is a forward-thinking technology company dedicated to innovation and the creation of cutting-edge solutions. With a commitment to excellence, we specialize in providing innovative solutions with advanced motion and aerosol generation technologies.

Our mission is to simplify and empower lives across various industries, including medical, pharma, aerospace, and industrial automation. Tekceleo's diverse team of experts collaborates to drive technological advancements and deliver results that exceed expectations. We're not just a company, we're a catalyst for progress, and we invite you to join us on this exciting journey.



KEY FACTS



2 Patent Families



A unique Know-How



75% of Sales Abroad

Evaluation Kit – Conditions of Use

Warning and Best Practices

1. General Characteristics

Liquids :

- Reference liquid for standard use of H-T45 nozzles is Reverse Osmosis (RO) Water, with a **>25 $\mu\text{S}/\text{cm}$** conductivity.
- For operation, avoid use of liquid with conductivity inferior at **25 $\mu\text{S}/\text{cm}$** (i.e. pure, deionized or distilled water).
- For operation, avoid use of viscous liquid (information on demand).

Environment of Use :

- Nozzle can sustain a temperature from **-20°C to +65°C**, range of temperature can be increased on demand (up to +120°C).
- Nozzle can sustain very high relative humidity but are not fully waterproof, avoid submerging it.

Common Risks :

- Clogging : nozzle can be clogged over time. Make sure to use a liquid that has low risk of deposit over time (filtered).
- Material compatibility : make sure to use liquid that are compatible with SS316L and HDPE.

Cautions and Warnings :

- Fluidic pressure applied to the system should not exceed **0,1 bar**.
- The H-T45 is a gravity fed design. Make sure the maximum tilt for the aerosol head is **45°**.
- **Do not fill more than 10ml of liquid** in the tank.
- Beware **when using 24 VDC, make sure the switch is set to 24VDC before powering the ECU**, or you'll damage the material.

Evaluation Kit – Conditions of Use

General Maintenance

2. Maintenance

Preventive maintenance :

- In case of use of corrosive and/or liquid with risk of clogging, it is recommended to set a cleaning routine by purging the system and making it operates with RO or distilled water for a short period of time.

Cleaning :

- Nozzle and system can be cleaned using ethanol-based biocide.

Corrective maintenance :

- Use 1/100 white vinegar to unclog the nozzle, or organic solvent for more than 1 minute.

Best Practices :

- Always check the liquid you'll use, if you have any interrogation contact Tekceleleo's team.
- Setting up a regular cleaning procedure in case of risk with your liquid will greatly increase nozzle lifespan and performance.

P&S T45 – Kit Presentation

Evaluation kit for Tekceleo's Micronice Technology

The purpose of this kit is for you to easily use, test, evaluate and implement Tekceleo's unique aerosol generation technology.

To understand more about our technology, you can consult our website :

www.tekceleo.com

Tekceleo's team is here to help you moving forward in your use case, for information, this kit intended use is for :

- **Directly use** our technology, as this kit is a standalone system that can be already used.
- **Evaluate** our technology, in order to ensure its viability for your project.
- **Prototype** : all the parts of this kit are modular and can be implemented in a prototype.
- **Be integrated** directly in your device, as a precise spraying device.



Kit Presentation – Presentation of Parts

Content and included parts of this kit



**H-T45 ELECTRONIC
SPRAYER**



**ECU NEB MXX
WITH CASING**



**PROTECTIVE
CAP**



TRIPOD



**12V POWER
SUPPLY**



**TERMINAL
BLOCK**



**MINI TERMINAL
BLOCK**



IHM P&S MXX

Kit Presentation – Technical Datasheet

H-T45 Nozzle Datasheet

| H-T45 Nozzle Outputs | | | |
|----------------------|---------------------------|--------------------------------------|------------------------------------|
| Nozzle Ref | Droplet Size (+/- 15%) | Nominal Output ml.mn (+/- 20%) | Nominal Output L.h (+/- 20%) |
| H-T45 – M05 | 05 µm | 0,8 ml.mn | 0,05 L.h |
| H-T45 – M08 | 08 µm | 2,5 ml.mn | 0,15 L.h |
| H-T45 – M12 | 12 µm | 5,5 ml.mn | 0,33 L.h |
| H-T45 – M20 | 20 µm | 8 ml.mn | 0,48 L.h |
| H-T45 – M50 | 50 µm | 35 ml.mn | 2,1 L.h |

| H-T45 Nozzle Inputs | | | |
|---------------------|---|-----------------------|---------------------------|
| Nozzle Ref | Nozzle Power Supply | Water Supply System | Water Supply Max Pressure |
| H-T45 – M05 | 60cm standard cable length Connector : microfit 3.0 2P | 10 mL integrated tank | <0,1 bar |
| H-T45 – M08 | | | |
| H-T45 – M12 | | | |
| H-T45 – M20 | | | |
| H-T45 – M50 | | | |

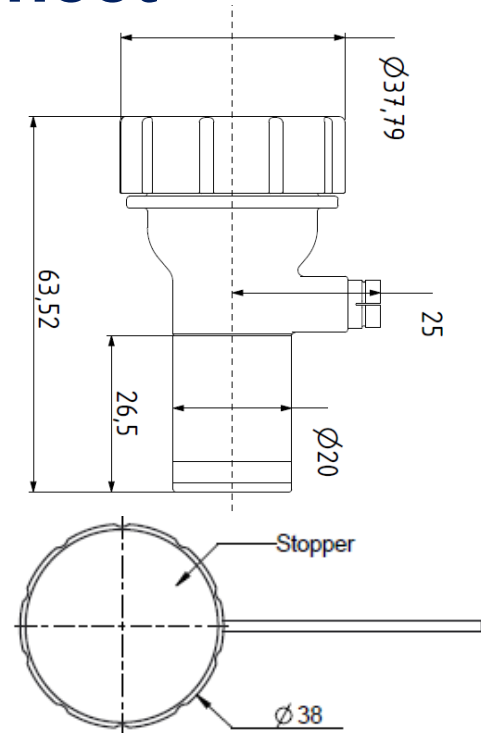

**H-T45 NOZZLE DIMENSION
(3D FILES UPON REQUEST)**

Kit Presentation – Technical Datasheet

Electronic Control Unit (ECU) Datasheet

| H-T45 Electronic Control Unit (ECU) | |
|-------------------------------------|---|
| Characteristics | Values |
| Supply Voltage | Terminal Block Connector 12 or 24 Vdc (switch) <i>Beware when using 24 VDC, make sure the switch is set to 24VDC before powering the ECU, or you'll damage the material</i> |
| Current Consumption (per nozzle) | 180 mA – 300 mA |
| Nebulization | Power : Led always ON Nozzle ON : Led ON Nozzle OFF : Led OFF |
| Time Response | < 1,5 ms |
| Dimensions | 82,4 x 76 x 45 mm |
| PWM or Analog Control | Mini Terminal Block Connector PWM : 3,3V at 150 Hz (switch) Analog Control : 0-10 V (switch) |

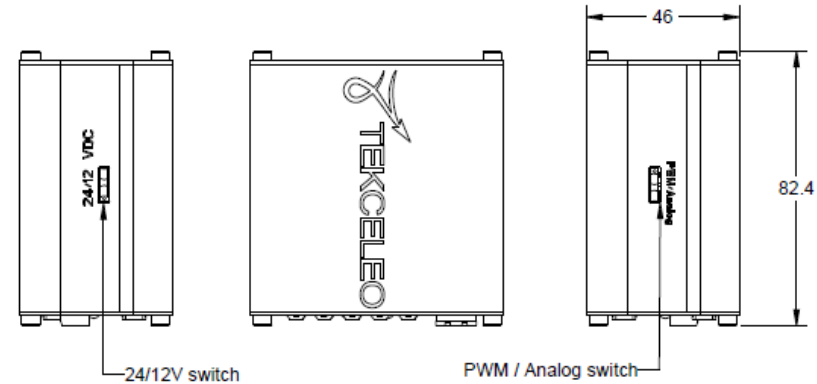
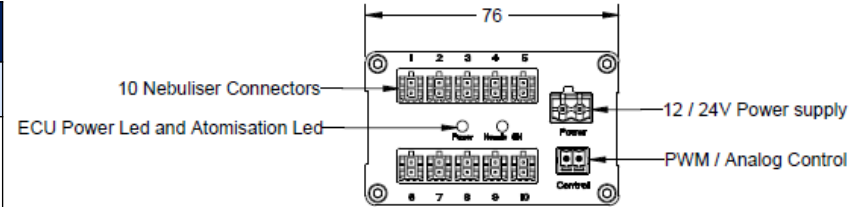

Make sure to verify the flowrate before powering the ECU



Make sure to verify the flowrate control switch before operating the ECU

**H-T45 ECU DIMENSION
(3D FILES UPON REQUEST)**

Kit Presentation – Technical Datasheet

Electronic Control Unit (ECU) – HMI Set Up



Operation with the HMI :

Please make sure that the ECU is setup with

12VDC + PWM



Operation without the HMI :

You can setup the ECU with

**12VDC or 24VDC + PWM
or
12VDC or 24VDC + Analog**

Kit Presentation – Technical Datasheet

Electronic Control Unit (ECU) – Polarity wiring



Polarity wiring must be respected as shown in the picture at the right

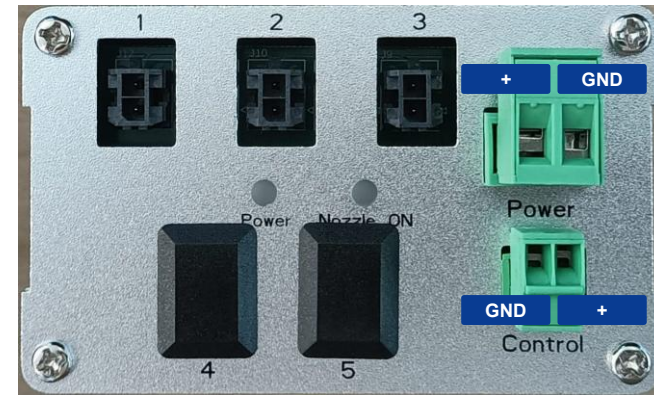

ECU FRONT PANEL

Kit Presentation – Technical Datasheet

Human Machine Interface (HMI) - Touch Screen Display

| H-T45 Human Machine Interface (HMI) | |
|-------------------------------------|--|
| Characteristics | Values |
| Supply Voltage | 12 Vdc |
| Current Consumption (per nozzle) | 150 mA |
| Cables Length | HMI Power Supply : 80 cm HMI – ECU cable : 50 cm |
| Dimensions | HMI : 123 x 66,5 x 16,2 mm Touch-Screen : 3,5 inch |
| Nebulizer Control | Touch ON/OFF |
| Flowrate Control | Nebulizer : 1% increment from 0% to 100% |
| Loop-Time Cycle Control | Delay : choice of time before beginning of a cycle ON/OFF cycle : choice of a time ON and a time OFF for alternating cycles Number of Cycles : choice of number of cycle or Infinite cycles |

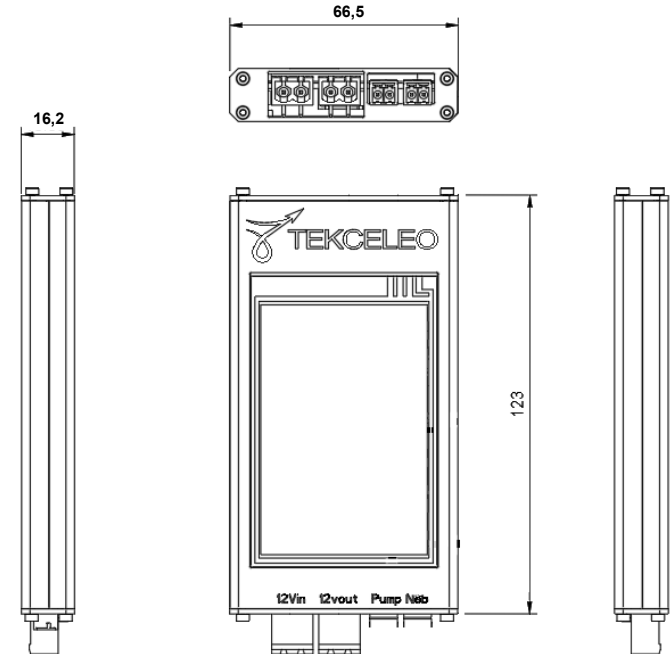

Kit Presentation – Technical Datasheet

Integrated tank specifications



Please make sure not to fill more than 10ml of liquid in the tank. This might lead to dripping.

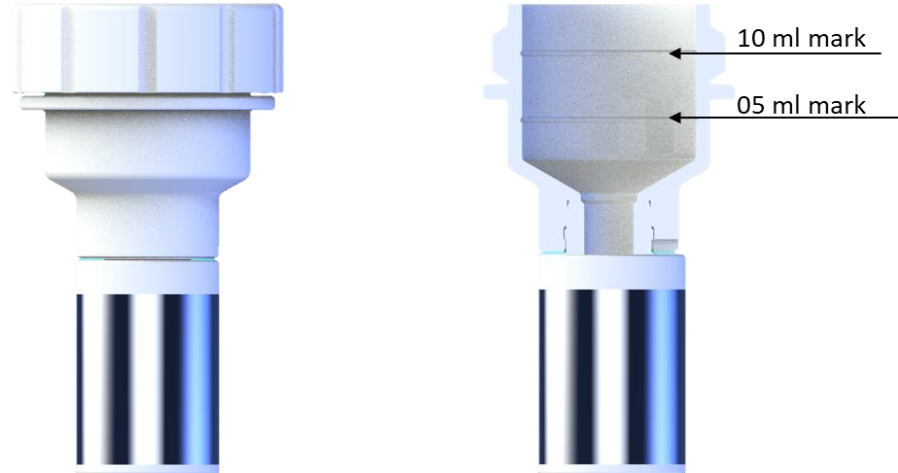

Evaluation Kit – Configuration & Set-up

Instruction to set-up and start the P&S T45 Kit

- Unscrew the cap located on the nebulizer's integrated tank.
- Fill in the integrated tank with the liquid you want to nebulize.
- Make sure the maximum tilt for the aerosol head is 45°.
- For the electronic assembly please make sure to plug the 12V power supply to the 12Vin of the IHM P&S at the very end :
 1. Connect the IHM P&S to the ECU NEB :
 - “12Vout” connector to “Power” connector
 - “Neb” connector to “Control” connector
 2. Connect the H-T45 electronic sprayer to the ECU NEB via the “microfit 3.0 2P” cable.
 3. Connect the “12V power supply” to the “12Vin” of the IHM P&S and then follow the instructions on the **IHM P&S : Quick Start Guide**.

| HMI P&S MXX Control features : Loop Time Cycle Control | |
|--|--|
| Flow rate | Press "+" or "-" to select the nebulizer flow rate (0% to 100% variation). |
| Delay | Choice of x (seconds/minutes/ hours) which will correspond to the time before the beginning of a cycle. |
| On/Off Cycle | Choice of x (seconds/minutes/hours) ON and x (seconds/minutes/hours) OFF which will correspond to the activation and stop time after the end of the timer. |
| Number of cycles or infinite | Choose a number of cycles with the "+" or "-" buttons or select the "infinite" button to choose an infinite cycle. When the "infinite" button is activated, the number of cycles displayed is 0. Please deactivate the "infinite" button to choose a number of cycles. |

Evaluation Kit – Configuration & Set-up

Cable Management Schematics

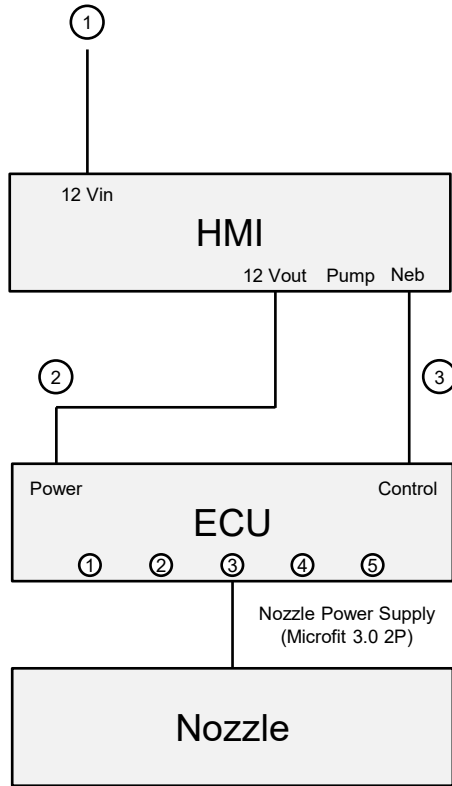
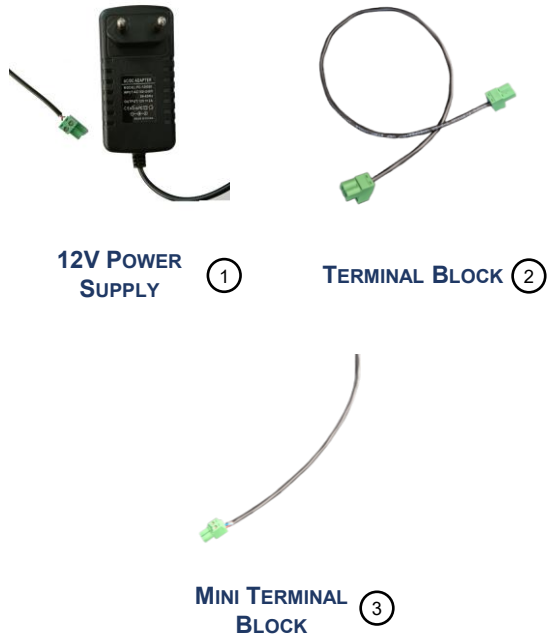

Please do not use the Pump connector of the HMI when using a T45 nozzle

Evaluation Kit – Electronic Control - PWM

Overview of Control Methodology – Nozzle ECU

Implementing ON/OFF and Flowrate Control with PWM :

- Use the connector terminal block
- PWM : 3,3V at 150 Hz
- PWM control :
 - 100% Duty Cycle : ON (150 Hz frequency)
 - 0% Duty Cycle : OFF (150 Hz frequency)
- From 0% to 100% : flowrate is linearly proportional to the PWM duty cycle. Please refer to the attached graph.



Relationship between Aerosol Flow Rate and PWM Duty Cycle

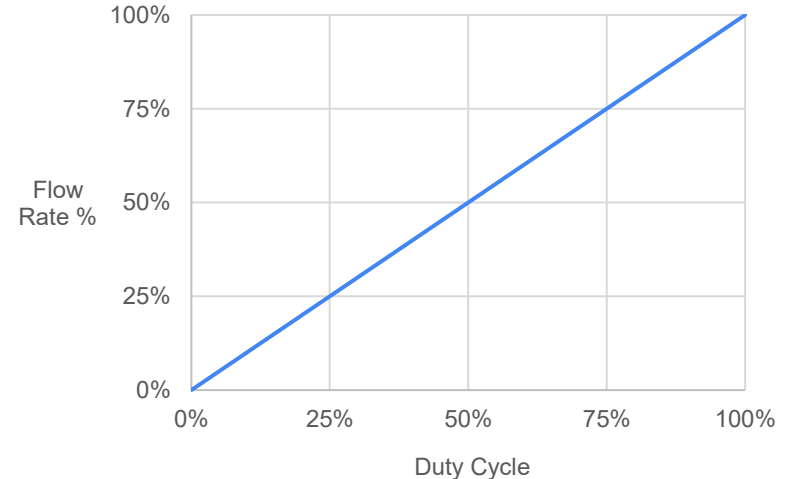

Important Notes :

- Default state of the electronic control **when switch is on PWM** is always ON at 100% flowrate when powered.

Evaluation Kit – Electronic Control - Analog Control

Overview of Control Methodology – Nozzle ECU

Implementing ON/OFF and Flowrate Control with Analog Control :

- Use the Mini terminal block connector
- Analog Control :
 - 10V = 100% flowrate = ON
 - 0V = 0% flowrate = OFF
- From 0V to 10V : flowrate is linearly proportional. Please refer to the attached graph.



Important Notes :

- Default state of the electronic control **when switch is on ANALOG** is always OFF when powered.

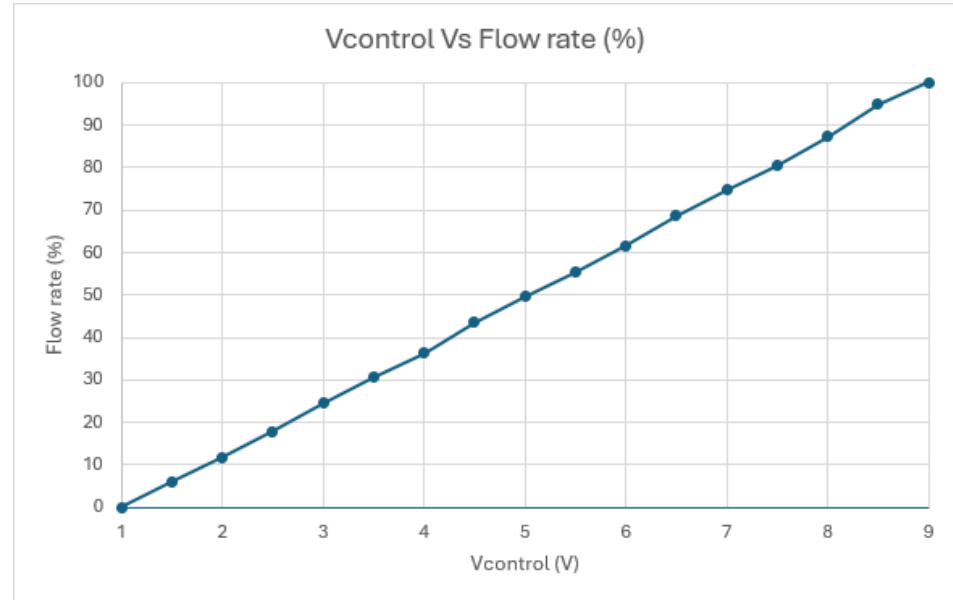

Evaluation Kit – Technical Support

Tekceleo's offer a complete technical support

- Directly contact your salesperson for any question. You can also directly contact Tekceleo using the contact@tekceleo.fr email address.
- In case of any trouble or issue you can freely open a support ticket by following this process :
 - Send an email to support-neb-1@tekceleo2.odoo.com
 - Object : order number + name of company.
 - Content : explain the problem you're experiencing and join as many data, picture or video that you can to help us troubleshoot your problem.
- Tekceleo's team will get back to you as soon as possible to troubleshoot and resolve your problem.

At any point of your project, you can contact Tekceleo for help regarding uses, integration or development project. We can also offer customization and engineering services if needed.

CONTACT US



www.tekceleo.com



(+33) 04.92.28.05.16.



contact@tekceleo.fr



[LinkedIn](#)